

UNITED STATES PATENT AND TRADEMARK OFFICE

---

BEFORE THE PATENT TRIAL AND APPEAL BOARD

---

CISCO SYSTEMS, INC.,  
Petitioner,

v.

C-CATION TECHNOLOGIES, LLC,  
Patent Owner.

---

Case IPR2014-00454  
Patent 5,563,883

Before KRISTEN L. DROESCH, KALYAN K. DESHPANDE,  
BARBARA A. BENOIT, LYNNE E. PETTIGREW, and  
MIRIAM L. QUINN, *Administrative Patent Judges*.

DROESCH, *Administrative Patent Judge*.

DECISION  
Denying Institution of *Inter Partes* Review  
*37 C.F.R. § 42.108*

## I. INTRODUCTION

Cisco Systems, Inc., (“Petitioner”) filed a Petition<sup>1</sup> (Paper 7, “Petition” or “Pet.”) to institute an *inter partes* review of claims 1–20 (“the challenged claims”) of U.S. Patent No. 5,563,883 (“the ’883 Patent”). See 35 U.S.C. §§ 311-19. C-Cation Technologies, LLC (“Patent Owner”) timely filed a Preliminary Response to the Petition. Paper 10 (“Prelim. Resp.”) We determine that, under 35 U.S.C. § 314(a), the information presented in the Petition does not demonstrate a reasonable likelihood that Petitioner would prevail with respect to at least one of the challenged claims.

### A. Related Proceedings

Petitioner indicates the ’883 Patent is at issue in *C-Cation Technologies, LLC v. Time Warner Cable Inc.*, No 2:14-cv-0030 (E.D. Tex. 2014). Pet. 1. Petitioner is a named defendant in the aforementioned proceeding. Claims 1, 3, 4, and 14 of the ’883 Patent are also the subject of a petition for *inter partes* review filed by ARRIS Group (IPR2014-00746, Paper 1). However, a decision on institution has not been made in that case.

### B. The ’883 Patent (Ex. 1002)

The ’883 Patent relates to a “method and apparatus to support two-way multi-media communication services on a multiple access communication system, which comprises a central controller, a shared transmission media, and a plurality of remote terminals dispersed throughout the network.” Ex. 1002, Abs.; see *id.* at col. 2, l. 65–col. 3, l. 1.

---

<sup>1</sup> “Petition” and “Pet.” refer to the Corrected Petition filed March 12, 2014.

Figure 1 of the '883 Patent, is reproduced below:

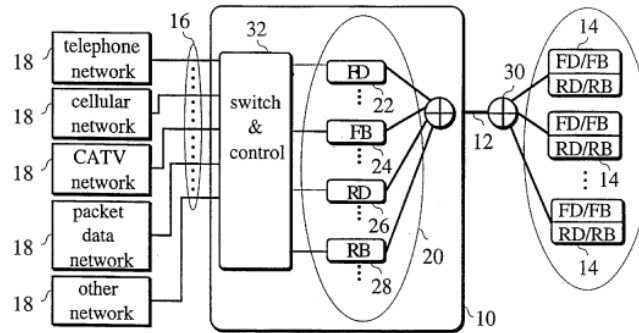

Figure 1 illustrates multiple access communication system architecture with interconnections between remote terminals 14, central controller 10, and wide area networks 18. *Id.* at col. 4, ll. 21–25. Communication channels 16 are provided to wide area networks 18, and communication channels 20 are provided for supporting remote terminals 14. *Id.* at col. 5, ll. 12–15. “All communication signals between central controller 10 and remote terminals 14 are multiplexed onto shared transmission media 12.” *Id.* at col. 5, ll. 21–23. Central controller 10 comprises switch and control mechanism 32; transmitters, called forward signaling data channel (FD) 22 and forward traffic bearer channel (FB) 24; and receivers, called reverse signalling data channel (RD) 26 and reverse traffic bearer channel (RB) 28. *Id.* at col. 5, ll. 15–21, 31–36; *see id.* at col. 12, l. 36–col. 13, l. 1; *see also id.* at col. 5, ll. 1–2; col. 12, l. 36–col. 13, l. 1; Fig. 16 (describing the components of central controller 10).

Figure 17 of the '883 Patent, is reproduced below:

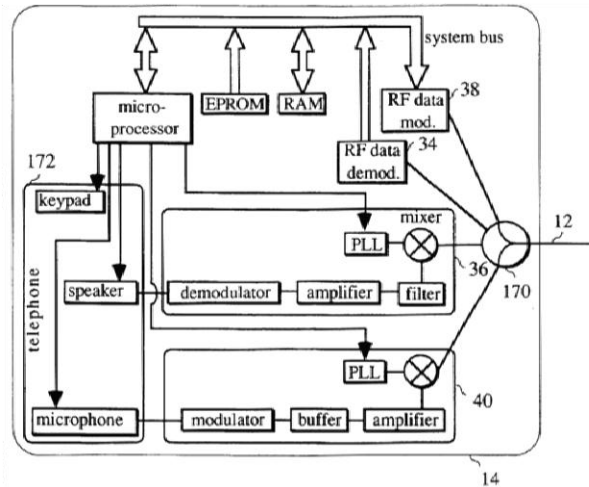

Figure 17 illustrates a diagram of remote terminal 14. *Id.* at col. 5, ll. 3–4. Remote terminal 14 comprises transmitter 40 and receiver 36 for communication on shared transmission media 12 (i.e., FB, RB), and radio frequency (RF) data modulator 38 and RF data demodulator 34 for signalling data channels (i.e., FD, RD). *Id.* at col. 13, ll. 40–45; *see id.* at col. 5, ll. 46–52. Transmitter 40, receiver 36, data modulator 38, and data demodulator 34 are capable of tuning to the assigned RF frequency. *Id.* at col. 13, ll. 45–47. Duplexer 170 combines the communication signals to be transmitted and duplicates the communication signals from shared transmission media 12 to receivers 34, 36. *Id.* at col. 13, ll. 47–51. A micro-processor communicates with Erasable Programmable Read Only Memory (EPROM), Random Access Memory (RAM), RF data demodulator 34, and RF data modulator 38 via a system bus. *Id.* at col. 13, ll. 51–53. Telephone set 172 includes a keypad, speaker and microphone. *Id.* at col. 13, ll. 54–55.

The '883 Patent additionally discloses a polling and registration process at central controller 10 (Ex. 1002, col. 4, ll. 33–34; col. 7, ll. 50–67; Fig. 4); and a registration, channel allocation, terminal assignment, and

reassignment process at central controller 10 (*id.* at col. 4, ll. 37–39; col. 8, ll. 16–55; Fig. 6).

### *C. Illustrative Claim*

Claims 1, 6, 14, and 19 are independent claims. Claims 2–5 depend from claim 1, claims 7–13 depend from claim 6, claims 15–18 depend from claim 14, and claim 20 depends from claim 19. Claim 19, reproduced below, is illustrative.

19. In a multiple access communication system having a central controller, a plurality of communication channels, and a plurality of remote terminals, each of said plurality of remote terminals comprising:

- (a) user traffic transmitting means for transmitting user traffic on an assigned communication channel;
- (b) user traffic receiving means for receiving user traffic on an assigned communication channel;
- (c) signalling data transmitting means for transmitting signalling data on an assigned communication channel;
- (d) signalling data receiving means for receiving signalling data on an assigned communication channel;
- (e) user interfacing means comprising a telephone with a keypad;
- (f) system controlling means for controlling the communication system comprising a micro-processor and associated EPROM and RAM and
- (g) communication controlling means for tuning said signalling data transmitting means and for tuning said signalling data receiving means under control of said central controller a pair of assigned communication channels via said micro-processor and associated EPROM and RAM.

## II. ANALYSIS

### *A. Prior Art*

U.S. Patent No. 4,533,948	(“McNamara”)	Ex. 1012
U.S. Patent No. 4,742,512	(“Akashi”)	Ex. 1016
U.S. Patent No. 5,355,374	(“Hester”)	Ex. 1013
U.S. Patent No. 5,377,192	(“Goodings”)	Ex. 1015
U.S. Patent No. 5,594,726	(“Thompson”)	Ex. 1009
U.S. Patent No. 5,625,651	(“Cioffi”)	Ex. 1008
“Multiaccess Protocols in Packet Communication Systems,” IEEE Transactions on Communications, vol. COM-28 no. 4, 1980 (“Tobagi”)		Ex. 1011
“Modeling and Analysis of Computer Communication Networks,” 1st ed., Jeremiah F. Hayes, 1984 (“Hayes”)		Ex. 1010
“A Demand-Adaptive Media Access Protocol for Metropolitan Area Networks,” by Semir Sirazi, 1986 (“Sirazi”)		Ex. 1014
MPT 1327 A Signalling Standard for Trunked Private Land Mobile Radio Systems 1988 (collectively “MPT”)		Ex. 1005
MPT 1343 Performance Specification 1988 (collectively “MPT”)		Ex. 1006

### *B. Asserted Grounds of Unpatentability*

Petitioner contends the challenged claims are unpatentable under 35 U.S.C. §§ 102 and 103 based on the following grounds (Pet. 3–4):

<b>Ground</b>	<b>Claims Challenged</b>	<b>Basis</b>	<b>Reference[s]</b>
1	1–4, 6, 7, 10, and 11	§ 102	MPT
2	1, 6–8, 10, 11, and 14–20	§ 102	Cioffi
3	14–20	§ 102	Thompson
4	6, 7, 12, and 13	§ 102	Hayes

5	1–4, 6, 7, 10, and 11	§ 103	MPT
6	1, 6–8, 10, 11, and 14–20	§ 103	Cioffi
7	14–20	§ 103	Thompson
8	6, 7, 12, and 13	§ 103	Hayes
9	1	§ 103	MPT in view of Cioffi
10	6 and 7	§ 103	Hayes and/or MPT
11	2	§ 103	MPT in view of Cioffi, Thompson, and Tobagi
12	3	§ 103	MPT in view of Thompson, McNamara, and Hester
13	4	§ 103	MPT in view of Thompson, and Sirazi
14	5	§ 103	MPT in view of Thompson, Hester, and Goodings
15	8	§ 103	Cioffi in view of Hayes and/or MPT
16	9	§ 103	Cioffi in view of Akashi
17	9	§ 103	Cioffi in view of Akashi, Hayes, and MPT
18	10 and 11	§ 103	MPT in view of Hayes or Cioffi
19	12 and 13	§ 103	Hayes in view of MPT and/or Cioffi
20	14–20	§ 103	Thompson in view of Cioffi

*C. Incorporation by Reference*

We first address the propriety of Petitioner’s use of footnotes listing certain paragraphs of the Declaration of Dr. Sumit Roy (Ex. 1001). *See* Pet. 17–19, 24–25, 27–34, 37, 39, 41–43. For example, section VII-A of the Petition presents five asserted grounds that claim 1 is unpatentable, spanning approximately seven pages, including a three-page claim chart. *See id.* at 17–24 (section VII-A). Section VII-A, however, includes four footnotes citing Dr. Roy’s Declaration. *See id.* at 17 n.6, 18 nn.7–8, 19 n.9. The

footnotes cite a total of seventeen pages, including eleven pages of claim charts, of Dr. Roy's Declaration—substantially more pages than section VII-A in the Petition. *See, e.g., id.* at 18 n.8 (citing Ex. 1001 ¶¶ 257–64 (referring to approximately seven pages of Dr. Roy's Declaration, including a four-page claim chart)), *id.* at 19 n.9 (citing Ex. 1001 ¶¶ 265–70 (referring to approximately eight pages of Dr. Roy's Declaration, including a seven-page claim chart)). The practice, here, of using footnotes to cite large portions of another document, without sufficient explanation of those portions, amounts to incorporation by reference.<sup>2</sup>

Moreover, the claim charts in the Petition cite to other claim charts included in Dr. Roy's Declaration. Using claim 1 as an example, the claim chart indicates the prior art descriptions that purportedly correspond to the limitation “(a) establishing communications between said central controller and said plurality of remote terminals via a plurality of signalling data channels, each of said remote terminals being initially assigned to a pair of predetermined signalling data channels.” Pet. 21. For this limitation, the claim chart cites ¶ 264 of Dr. Roy's Declaration for two of the grounds asserted against claim 1 (i.e., Grounds 1 and 5). Paragraph 264 consists of nearly five pages, four pages of which is a claim chart. For two other grounds asserted against claim 1 (i.e., Grounds 2 and 6), the claim chart cites ¶ 270 of Dr. Roy's Declaration, which consists of another six-page claim chart, to explain how the asserted prior art discloses limitation (a). *Id.* The

---

<sup>2</sup> BLACK'S LAW DICTIONARY 766-67 (6th ed. 1990) (defining incorporation by reference as “[t]he method of making one document of any kind become a part of another separate document by reference to the former in the latter, and declaring that the former shall be taken and considered as a part of the latter the same as if it were fully set out therein”).



practice, here, of citing to other claim charts in another document also amounts to incorporation by reference.

Further, the Petition includes citations to the Declaration to support conclusory statements for which the Petition does not otherwise provide an argument or explanation. For example, concerning limitation (a) in claim 1, the claim chart indicates, concerning “Grounds 1 and 5” identified by Petitioner: “MPT Spec. discloses limitation (a) of claim 1. Roy Dec. at ¶¶ 54, 67, 261, and 264” and provides a one sentence quotation from the reference and several citations to the reference. Pet. 21. In another example concerning claim 1, the Petition asserts:

Each of MPT Specification and Cioffi also discloses dynamic signal allocation in a multi-access system, including each and every feature of claim 1, arranged in the same manner as claim 1 requires, and thus anticipates the claim. In the alternative, it would have been obvious for a person of ordinary skill in the art to modify the teachings of each of MPT Specification and Cioffi or to combine the teachings of MPT Specification and Cioffi to practice claim 1. The prior art references are in the same field of endeavor and the combination allows the extension of services from one system to another.

*Id.* at 17–18. This conclusory paragraph is followed by a footnote, citing to ¶¶ 271–273 of Dr. Roy’s Declaration—one and a half pages indicating the combinations would have been “well within the ordinary creativity of a person of ordinary skill in the art” and providing reasons why one would have combined the teachings of the references. This practice of citing the Declaration to support conclusory statements that are not otherwise supported in the Petition also amounts to incorporation by reference.

It is improper to incorporate by reference arguments from one document into another document. 37 C.F.R. § 42.6(a)(3). One purpose of the prohibition against incorporation by reference is to eliminate abuses that arise from incorporation. Rules of Practice for Trials Before The Patent Trial and Appeal Board and Judicial Review of Patent Trial and Appeal Board Decisions; Final Rule, 77 Fed. Reg. 48,612, 48,617 (Aug. 14, 2012); *see also DeSilva v. DiLeonardi*, 181 F.3d 865, 866-67 (7th Cir. 1999) (Incorporation “by reference amounts to a self-help increase in the length of the [] brief[,]” and “is a pointless imposition on the court’s time. A brief must make all arguments accessible to the judges, rather than ask them to play archeologist with the record.”). In the Petition before us, incorporation by reference of numerous arguments from Dr. Roy’s 250-page Declaration into the Petition serves to circumvent the page limits imposed on petitions for *inter partes* review, while imposing on our time by asking us to sift through over 250 pages of Dr. Roy’s Declaration (including numerous pages of claim charts) to locate the specific arguments corresponding to the numerous paragraphs cited to support Petitioner’s assertions.

Accordingly, we will not consider arguments that are not made in the Petition, but are instead incorporated by reference to the cited paragraphs and claims charts of Dr. Roy’s Declaration.

#### *D. Unpatentability Grounds Based on Anticipation*

The Petition provides characterizations of the claimed subject matter, brief summaries of the applied references, and general assertions that the applied references disclose the claimed subject matter. *See* Pet. 17–21, 24–30, 32–34, 37–40, 42–43, 45–50. The Petition further includes claim charts

providing quotations and citations from each of the applied references. *See id.* at 21–24, 26–31, 34–41, 44–47, 50–59.

A petition for *inter partes* review must identify how the construed claim is unpatentable under the statutory grounds on which the petitioner challenges the claims, and must specify where each element of the claim is found in the prior art patents or printed publications relied upon. 37 C.F.R. § 42.104(b)(4). Similarly, 37 C.F.R. § 42.22(a)(2) states that each petition must include “a detailed explanation of the significance of the evidence including material facts, and the governing law, rules, and precedent.” The Office Patent Trial Practice Guide suggests parties requesting *inter partes* review should “avoid submitting a repository of all the information that a judge could possibly consider, and instead focus on concise, well organized, easy-to-follow arguments supported by readily identifiable evidence of record.” 77 Fed. Reg. at 48,763 (Aug. 14, 2012). The Petition before us does not: (1) specify sufficiently where each element of the claims is found in the applied references, and (2) include a detailed explanation of the significance of the quotations and citations from the applied references. *See* 37 C.F.R. §§ 42.104(b)(4), 42.22(a)(2).

For example, independent claim 19 recites “system controlling means for controlling the communication system comprising a micro-processor and associated EPROM and RAM.” Petitioner asserts that claim 19 is anticipated by Cioffi and by Thompson. Pet. 3, 47–50, 56–59.

A portion of the claim chart from the Petition addressing the aforementioned limitation of claim 19 is reproduced below (Pet. 58–59):

<p>(f) system controlling means for controlling the communication system comprising a micro-processor and associated EPROM and RAM and</p>	<p><u>Grounds 3 and 7</u>          Thompson discloses limitation (f). Roy Dec. at ¶¶ 246, 252, 451, 456, 458-459; “... The CPU 308 is operative to control the assigned relationships between particular telephony lines, ingoing and outgoing, with predetermined carrier assignments in the reverse path and in the forward path, monitor the noise level in the reverse path, and assign DS0 channels in the reverse path commensurate with subscriber features and the like....” Thompson at 21:23-45; see also <i>Id.</i> at Figure 11</p>
	<p><u>Grounds 2 and 6</u>          Cioffi discloses limitation (f) of claim 19. Roy Dec. at ¶¶ 247, 252, and 461-463; “The central modem includes... a controller 60...” Cioffi at 5:30-36; see also <i>Id.</i> at 6:6-25; and 9:45-49  <u>Ground 20</u>          A combination of Thompson and Cioffi discloses limitation (f) of claim 19. Roy Dec. at ¶¶ 252, 459, 463, and 464-465</p>

Petitioner asserts in the claim chart that Thompson and Cioffi disclose limitation (f) and provides quotes and citations from Thompson and Cioffi that allegedly support the assertions. **The quotations provided in the claim chart do not specify expressly where the associated EPROM and RAM are disclosed by either Cioffi or Thompson.** We also are not persuaded the quotations provided in the claim chart show sufficiently that a person of ordinary skill in the art in the relevant time period would have understood those quotations to describe an associated EPROM and RAM, as recited in the claim. Furthermore, the Petition does not provide a detailed explanation of the significance of the quotations and citations from Cioffi and Thompson, and does not otherwise specify sufficiently where the EPROM and RAM are disclosed by Cioffi and Thompson. *See id.* at 47–50, 56–59; 37 C.F.R. §§ 42.104(b)(4), 42.22(a)(2).

We have reviewed the Petition as to the remaining claims and grounds of unpatentability based on anticipation, and have determined that the Petition provides similarly deficient analyses of the remaining grounds. Specifically, the remaining grounds also do not (1) specify sufficiently where each element of the claims is found in the applied references, and (2) include a detailed explanation of the significance of the quotations and citations from the applied references. Accordingly, on the record before us, the information presented in the Petition does not demonstrate a reasonable likelihood that Petitioner would prevail with respect to its assertions of unpatentability based on anticipation (i.e., Grounds 1 through 4).

*E. Unpatentability Grounds Based on Obviousness*

The question of obviousness is resolved on the basis of underlying factual determinations including: (1) the scope and content of the prior art, (2) any differences between the claimed subject matter and the prior art, (3) the level of skill in the art, and (4) where in evidence, so-called secondary considerations. *Graham v. John Deere Co.*, 383 U.S. 1, 17–18 (1966). Against this background, the obviousness of the claimed subject matter is determined. *Id.* “[R]ejections on obviousness grounds cannot be sustained by mere conclusory statements; instead, there must be some articulated reasoning with some rational underpinning to support the legal conclusion of obviousness.” *KSR Int’l Co. v. Teleflex Inc.*, 550 U.S. 398, 418 (2007) (quoting *In re Khan*, 441 F.3d 977, 998 (Fed. Cir. 2006)).

In addition to the deficiencies discussed above addressing Petitioner’s assertions based on anticipation, the Petition does not address meaningfully the scope and content of the prior art, and any differences between the claimed subject matter and the prior art. *See* Pet. 17–59. The Petition also

does not provide sufficient articulated reasoning with rational underpinning explaining why one with ordinary skill in the art would modify the teachings of the applied references to address those differences. **The Petition merely provides conclusory statements to support the assertions of obviousness.** *See id.* at 17–18, 24–25, 28, 30–33, 37, 39, 41–43, 45–48.

For example, Petitioner asserts that claim 19 would have been obvious over Cioffi and Thompson. *Pet.* 4, 47–50, 56–59. Petitioner asserts in the claim chart that a combination of Thompson and Cioffi discloses each of the limitations of claim 19, with citations to certain paragraphs of Dr. Roy’s Declaration. *Id.* at 56–59. Petitioner provides the following conclusions regarding the combined teachings of Thompson and Cioffi:

[i]t would have been obvious for a person of ordinary skill in the art . . . to combine the teachings of Thompson and Cioffi. The motivation to combine is in the prior art references: to implement different architectures that extend various services to users. The prior art references are in the same field of endeavor: multi-access communication protocols in multi-access communication systems and proposed solutions to common problems of multi-access communication protocols.

*Id.* at 47–48 (footnotes omitted). For exemplary claim 19, the Petition does not provide sufficient articulated reasoning with rational underpinning explaining which elements of Thompson would be combined with those of Cioffi, and why one with ordinary skill in the art would modify the teachings of Thompson in view of Cioffi’s teachings to arrive at the claimed invention.

We have reviewed the Petition as to the remaining claims and grounds of unpatentability based on obviousness, and have determined that the Petition provides similarly deficient analyses of the remaining grounds. Specifically, the remaining grounds also do not provide sufficient articulated

reasoning with rational underpinning explaining why one with ordinary skill in the art would modify the teachings of the applied references to arrive at the claimed invention. *See* Pet. 17–59. Therefore, on the record before us, the information presented in the Petition does not demonstrate a reasonable likelihood that Petitioner would prevail with respect to its assertions of unpatentability based on obviousness (i.e., Grounds 5 through 20).

*F. Time Bar Under 35 U.S.C. § 315(b) Based on Privity*

Patent Owner argues that Petitioner is a privy of at least one party that was served with a complaint for infringement of the '883 Patent more than one year prior to the date on which this Petition was filed, and therefore the Petition is barred under 35 U.S.C. § 315(b). Prelim. Resp. 57–60. Because the information presented in the Petition does not demonstrate a reasonable likelihood that Petitioner would prevail with respect to at least one of the challenged claims, we need not address Patent Owner's assertions that the Petition is barred under 35 U.S.C. § 315(b) based on privity.

III. CONCLUSION

Based on the record before us, the information presented in the Petition does not demonstrate a reasonable likelihood that Petitioner would prevail in showing that claims 1–20 are unpatentable.

IV. ORDER

Accordingly, it is ORDERED that the Petition for *inter partes* review is DENIED.

IPR2014-00454  
Patent 5,563,883

PETITIONER:

Mitchell G. Stockwell  
Michael S. Pavento  
Vaibhav P. Kadaba  
Russell A. Korn  
KILPATRICK TOWNSEND & STOCKTON LLP  
MStockwell@kilpatricktownsend.com  
MPavento@kilpatricktownsend.com  
WKadaba@kilpatricktownsend.com  
RKorn@kilpatricktownsend.com

PATENT OWNER:

Lewis V. Popovski  
Jeffrey S. Ginsberg  
David J. Kaplan  
David J. Cooperberg  
KENYON & KENYON LLP  
lpopovski@kenyon.com  
jginsberg@kenyon.com  
djkaplan@kenyon.com  
dcooperberg@kenyon.com